

# SM 100AK

---

2 way nearfield active monitor | owners manual

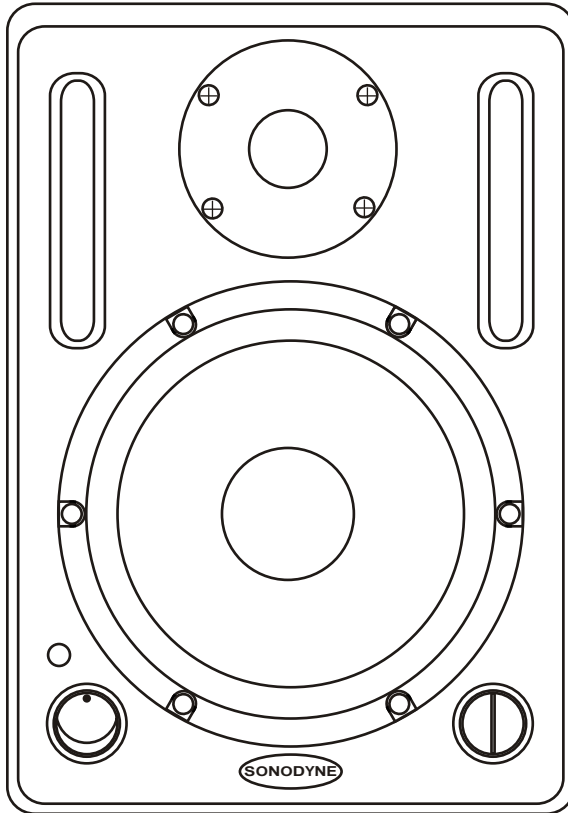

---

**SONODYNE**<sup>®</sup>  
www.sonodyne.com

## INTRODUCTION

Congratulations on your purchase of the SM 100Ak near field active studio monitor. The SM 100Ak has all the makings of a truthful reference device. The high grade transducers, the aluminium die cast rigid enclosure, the active amplification, the on board EQ, among others, result in sound that is neutral and transparent. You may thus depend on the SM 100Ak to accurately meet your professional monitoring needs.

## SAFETY

- Please ensure proper earthing.
- Please keep away from moisture.
- The equipment is capable of producing SPL in excess of 100 dB. Long term exposure may cause permanent hearing damage.
- Ensure that the speakers are not covered while in use. Restricted airflow at the rear of the unit will cause it to heat up.

## UNPACKING

While removing the units from the carton, please do not hold the speaker's front. The high frequency transducer is located near the top of the cabinet, on the front baffle; you may accidentally damage the transducer.

The best way to safely unpack the monitors is to open the top of the carton, keep the EP filler piece on, turn the entire box upside down and pull off the carton box. Then remove the filler pieces, the protective cloth and moulded baffle cover.

FIG. 1: FRONT PANEL

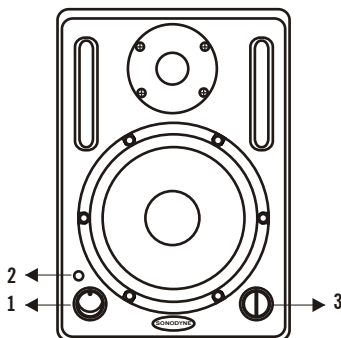
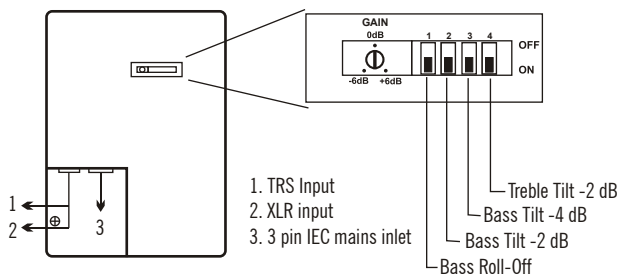

FIG. 2: REAR PANEL



# Controls and Features

---

---

## FRONT PANEL (refer to Fig. 1 on page 1)

1. **Power Switch:** This switch is used to turn power ON/OFF
2. **Power Indicator:** This lights up when power is ON
3. **Master Level Control:** This control increases or decreases the overall level. Full master level corresponds to 0 dB.

## REAR PANEL (refer to Fig. 2 on page 1)

- **GAIN:** The SM 100Ak has a variable gain control. The gain is factory set to 0 dB. With the level control on the front panel set to maximum position (fully clockwise) and an input signal of -6 dBu, the SM 100Ak will typically produce an output of 109 dB SPL at 1 meter in an anechoic environment.  
The variable gain setting allows the user to get a good sensitivity match when using either professional or semi-professional equipment. Using the gain control, the monitor can be set for inputs of -6 dBu to +6 dBu.
- **LF SWITCH (BASS ROLL-OFF):** Switch 1 when ON introduces a low frequency roll-off into the response curve. The effect of the roll-off (6 dB per octave @ 100 Hz) is shown in Fig. 6 on page 6.  
For many applications, removal of deep bass content allows you to raise the overall output level, permitting LOUD mixing. But, keep in mind that removing deep bass content from monitors may actually result in an inaccurate bass reproduction.
- **ROOM COMPENSATION (LF) (BASS TILTS):** Switches 2 & 3 when ON activates a filter @ 80 Hz, to reduce the low frequency output by 2 dB & 4 dB respectively. Engaging both switches produces a 6 dB roll-off. These functions can be used to compensate for the build-up of low frequencies that occur when the speakers are placed near walls or corners, or on the workbench surfaces. When the monitors are at a free standing position, away from walls and workbenches turn these switches OFF. The changes in low frequency response using switches 2 & 3 are shown in Fig. 7 on page 6.
- **ROOM COMPENSATION (HF) (HF TILTS):** Switch 4 introduces a high frequency response shelf cut of 2 dB above 4 kHz. This feature can be used if the testing room is 'fairly live' or the listening position is close to the speakers. But generally not used for applications in 'dead' rooms. The change in the frequency response when switch 4 is ON can be seen in Fig. 8 on page 6.

After you've studied the SM 100Ak's rear panel switches, do not hesitate to experiment with the settings and also monitor placement to get the best results.

# Installation • Fig. 3

## INSTALLATION

**ROOM PLACEMENT:** The SM 100Ak has a wide variety of placement options. Shown in Fig. 4 on page 4 is a typical stereo setup for near to mid-field monitoring. Shown in Fig. 3 is a typical 5 channel setup.

The monitors should be angled to directly face the listener. The center of the high frequency transducer should be on-axis with the ear level of the listener.

The low frequency compensation settings can be used when speakers are placed in close proximity to walls, corners and work surfaces.

**LISTENING DISTANCE:** The common listening position at mixing positions is generally 1 to 1.5 m for near field applications. For mid-field applications, 2-3 m is more likely. The stereo listening angle is more a matter of personal preference, but we recommend the angle should be around 60° as shown in Fig. 4 on page 4

**MOUNTING OPTIONS:** The SM 100Ak may be wall or floor mounted. (Optional) accessories are available.

### CONNECTORS

- **Audio:** The SM 100Ak has one balanced TRS and one 3 pin balanced XLR input. (refer to Fig. 2: rear panel on page 1) The pin configuration is shown in Fig. 5 on page 4. The wiring configuration for using unbalanced sources is also shown. (Please note that we strongly recommend against using unbalanced inputs.)
- **AC Power:** This is a 3 pin IEC type socket (see Fig. 2: rear panel on page 1) with integral fuse holder. The fuse is rated as 0.6A SB. Replace only with exact type and rating.

FIG. 3

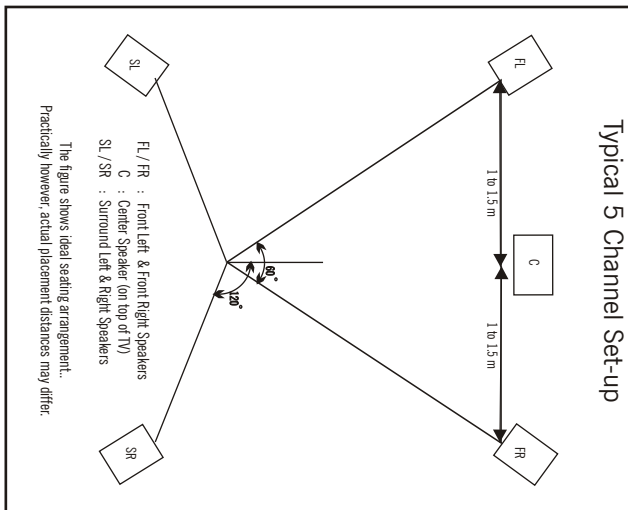

# Fig. 4 & 5 • Operation • Maintenance

**FIG. 4**

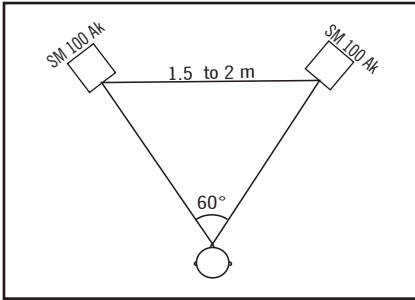

**FIG. 5**

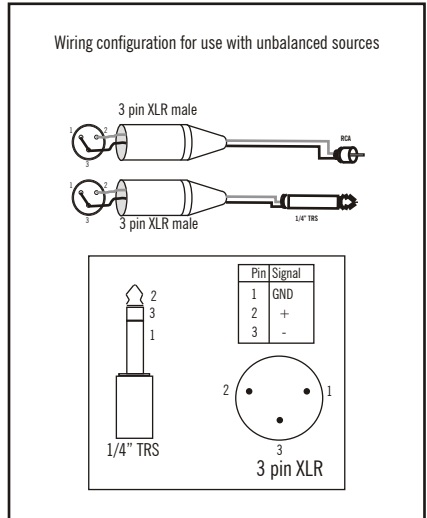

## OPERATION

- Connect the line level monitor signal from your mixer (or any other source) to the signal input on the SM 100Ak studio monitor using balanced cables (1/4" TRS / 3 pin XLR).
- Connect the supplied AC power cord to the IEC socket at rear panel.
- Keep the power switch at OFF position and turn down the master level on the front panel to minimum position.
- Switch on your mixer, but keep the master level control at minimum.
- Switch ON SM 100Ak. The blue power LED will light up. Ensure that the Input Sensitivity (Gain control at the rear panel) is set to 0dB
- Slowly turn up the Master level control of the SM 100Ak.
- Now, adjust the master volume on your mixer to a comfortably loud listening position.

### Note

- Your SM 100Aks' achieve their best bass response in a room that is optimized for bass reproduction. Factors such as room shape and volume, absence of acoustical treatment can prove to be a bane for optimal sound reproduction from the SM 100Aks. Therefore we have provided some compensation controls which you can use to optimize the frequency response of the speakers for any particular room. For the effect of these 'tilts' please refer to Fig: 6-8 on page 6.

## MAINTENANCE

No user serviceable parts inside the unit. All maintenance and repair work to be undertaken by qualified personnel only.

# Troubleshooting

---

---

**Symptom:** Device remains 'OFF'

- Make sure that the power cord is securely seated in the IEC socket and plugged all the way into the AC outlet.
- Make sure that the AC outlet is live (check with tester).
- Remove power cord and check the Fuse. If blown, then replace with exact type and rating.

**Symptom:** Device is 'ON' but no audio output

- Is the master level control on the front panel turned up? The gain control on the rear panel may be at minimum position.
- Is the signal source turned up? Make sure that the signal level from the device preceding the SM 100Ak is high enough to match the Input sensitivity (Gain control on rear panel).
- If either of the stereo pair is not producing sound, then switch the signal around. If the problem also switches sides, the problem is not the monitor. It could be a bad signal cable, or no signal from the mixer.

**Symptom:** Distorted sound

- Ensure secure connectivity of the TRS / XLR.
- Reduce signal level at mixer or reduce gain control of SM 100Ak at rear panel.
- Please monitor the signal with headphones. Distorted sound in headphones indicate that the problem lies in the signal source.

**Symptom:** Noise / Hum / Line interference

- Proper signal wiring between the mixer and the monitor eliminates the hum, buzz and all sorts of crackling noises. Make sure all connections are secure.
- If unbalanced sources are used, wire the connectors such that the unbalanced ground of the source is connected to the inverting pin (pin 3 for XLR, ring for TRS jack) and ground (pin 1 for XLR, sleeve for TRS jack). Improper cabling will result in unsatisfactory audio reproduction. (please refer to Fig. 5 on page 4)
- If a CATV cable is connected to the system, and a persistent mains hum occurs, disconnect it. If the hum goes away call the cable operator to check for proper cable grounding methods. Using BALUN transformers (1:1, isolated type) might solve the problem.
- Make sure that the signal cable is not routed near AC cables.
- If a light dimmer or triac-based device exists on the same AC circuit as the monitor, buzzing noises may occur. AC Line filters may eliminate the problem.

# Fig. 6, 7 & 8

FIG. 6

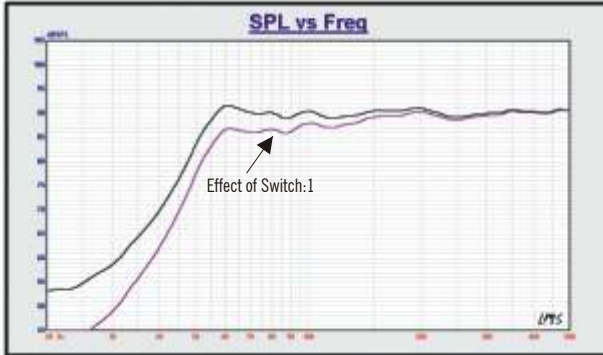

FIG. 7

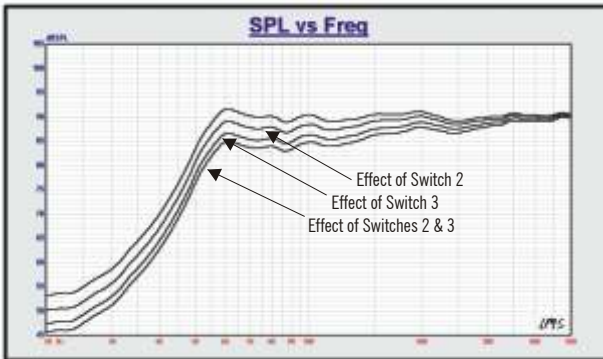
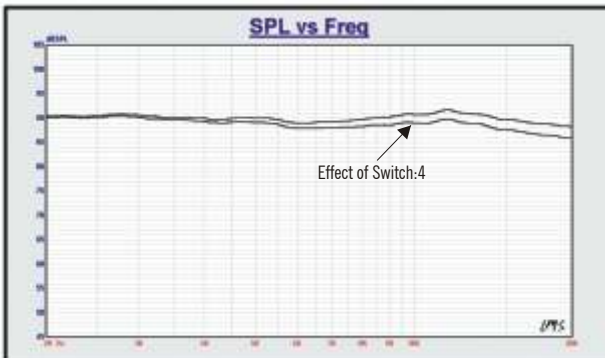

FIG. 8



# Specifications

DESCRIPTION	2 way nearfield active monitor
TRANSDUCER COMPLEMENTS	LF : Magnetically shielded 6.5" Kevlar cone woofer in composite poly-frame
	HF : Magnetically shielded 26mm silk – dome ferrofluid cooled tweeter with integral waveguide
ENCLOSURE TYPE	Vented, through twin front-firing aerodynamic port
SYSTEM	
OVERALL FREQUENCY RESPONSE	60 Hz ~ 22 kHz, ( $\pm 3$ dB)
USABLE FREQUENCY RANGE	50 Hz ~ 30 kHz, ( $\pm 10$ dB)
MAX. LONG TERM SPL, HALF SPACE	109 dB at 1m
HORIZONTAL BEAM WIDTH	90° (averaged between 5 ~ 14 kHz)
VERTICAL BEAM WIDTH	85° (averaged between 5 ~ 14 kHz)
TOTAL HARMONIC DISTORTION	65 Hz ~ 200 Hz <3% (at 95 dB SPL) >200 Hz <1%
AMPLIFIER AND CROSSOVER	
AMPLIFIER POWER BEFORE CLIPPING	LF: 80 W HF: 40 W
S/N RATIO (AT UNITY GAIN)	> 90 dB, referred to full output
AMPLIFIER THD AT RATED POWER	< 0.04 %
INPUT	
INPUT LEVEL FOR 109 DB SPL AT 1M	- 6 dBu
GAIN CONTROL RANGE	$\pm 6$ dB, with respect to U position
VOLUME CONTROL RANGE	> 70 dB
CMRR	> 65 dB
SUBSONIC FILTER	40 Hz, 12 dB/octave
CROSSOVER	4th order, Linkwitz Riley, 1.5 kHz crossover freq.
BASS TILT	- 2 dB, - 4 dB, - 6 dB @ 80 Hz
BASS ROLL-OFF	80 Hz, 6 dB/octave
TREBLE TILT	- 2 dB @15 kHz
CONTROLS : FRONT	Power Switch and Volume Control
CONTROLS : REAR	Gain control, 4 DIP switches for bass/treble tilts & bass roll-off
INDICATOR	Power ON /OFF
PROTECTION	Over current, Overheat , RFI, Switch on/ off transients
POWER REQUIREMENT	230 V AC, $\pm 10$ % , 50 Hz
POWER CONSUMPTION	200 VA Max.
MECHANICAL	
CABINET MATERIAL	Die-cast aluminum
FINISH	Black texture
MECHANICAL DIMENSION (W x H x D)	230 mm x 335 mm x 300mm
INTERNAL VOLUME/ NET WEIGHT	13 Litre / 10.5 Kg



## SONODYNE<sup>®</sup>

A product of the Mukherjee Innovation Centre

Manufactured by Sonodyne Technologies Pvt. Ltd, H.O.: 98 NB Block E New Alipore, Kolkata 700053, INDIA

Tel: +91 33 24570418, 24583406; Fax: +91 33 24787243; E-mail: response@sonodyne.com

Please visit us at [www.sonodyne.com](http://www.sonodyne.com)